

Tunnel ventilation sustainability – current status and trends

Dr Fathi Tarada



Motivation

- Peak power consumption in tunnels is driven by ventilation requirements, and can reach several megawatts
- How can this power consumption be reduced, to improve sustainability and to reduce costs?

Contents

- Longitudinal tunnel ventilation with jet fans
- Sources of inefficiency
- Jet fans with shaped nozzles
- Tunnel measurements and CFD
- Selection of correct jet fan technology
- Project example
- Questions and answers



Longitudinal tunnel ventilation with jet fans

Tunnel ventilation with jet fans

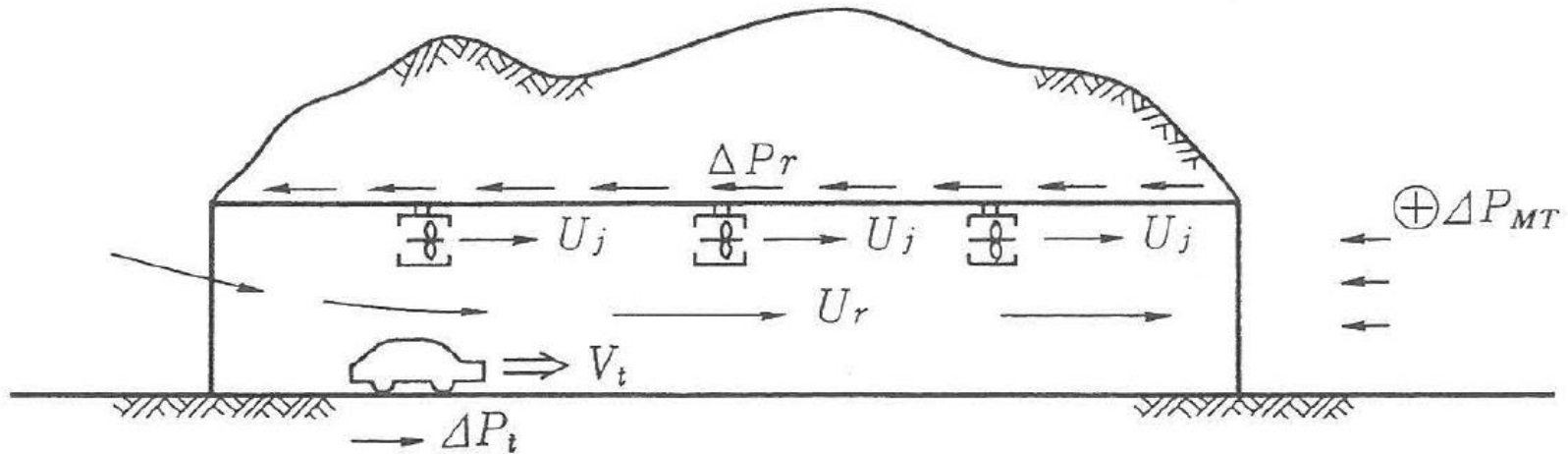

- Jet fans deliver a longitudinal thrust to the tunnel air
- Flow is induced from the inlet tunnel portal, and is discharged at the exit tunnel portal
- The jet fan thrust is designed to overcome aerodynamic pressure drops into, along and out of the tunnel



Sources of inefficiency

Sources of Jet Fan Inefficiency

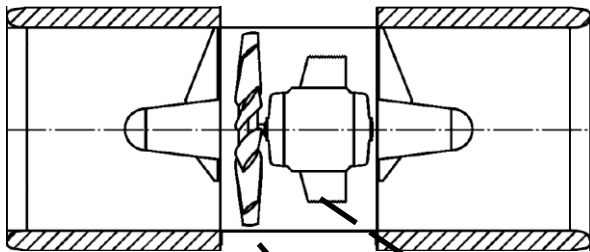

Aerodynamic friction
(against flow direction) –
25% to 80% efficiency

Motor efficiency:
over 90%

Fan efficiency: 40% to
70%



Jet fans with shaped nozzles

Jet Fan with Shaped Nozzles

The bellmouth deflects the discharge flow away from the tunnel surfaces, reducing the Coanda effect and hence avoiding the loss of thrust due to aerodynamic friction.

The inlet bellmouth is tilted away from the bounding tunnel surfaces, hence reducing their confining effects and increasing the mass flow

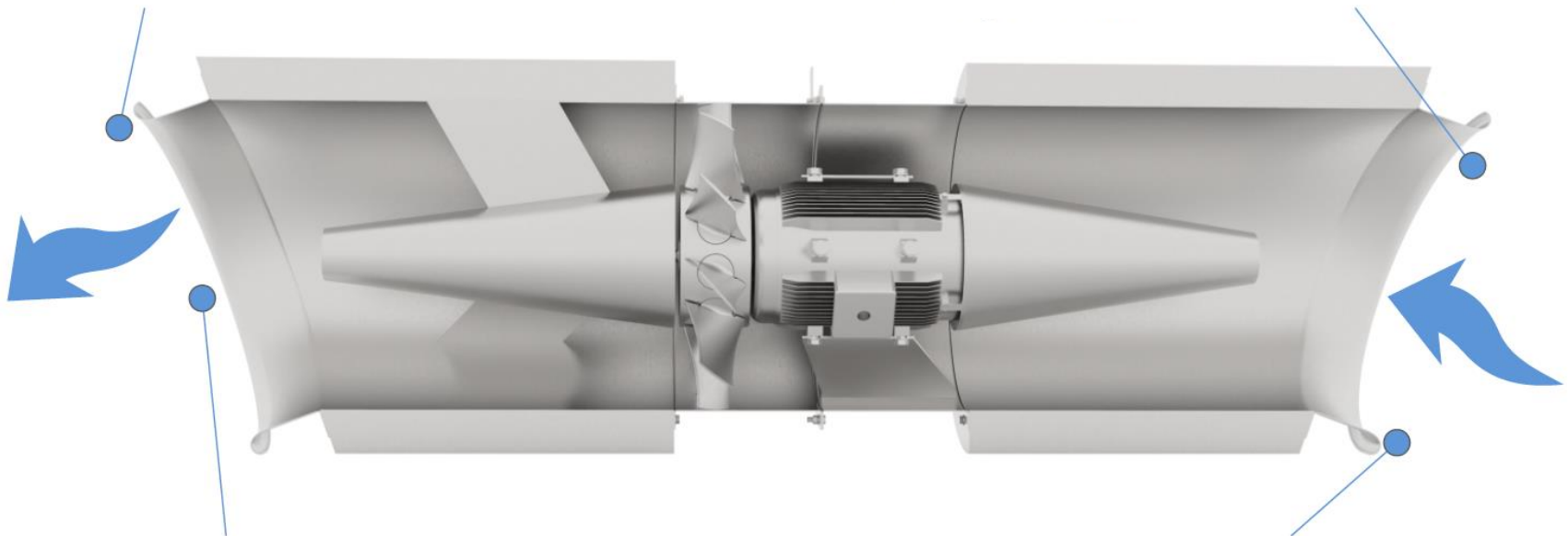

The circular bellmouth has an area greater than that of the fan, leading to a lower discharge velocity, reduced discharge pressure drop, increased mass flow, greater static pressure recovery and less aerodynamic shear on tunnel surfaces.

The inlet bellmouth smoothly guides the flow into the silencer, avoiding any flow separation. The inlet pressure drop is reduced by having a circular bellmouth that has a larger area than the fan, and this leads to a higher mass flow.

Outlet Flow from Shaped Nozzle

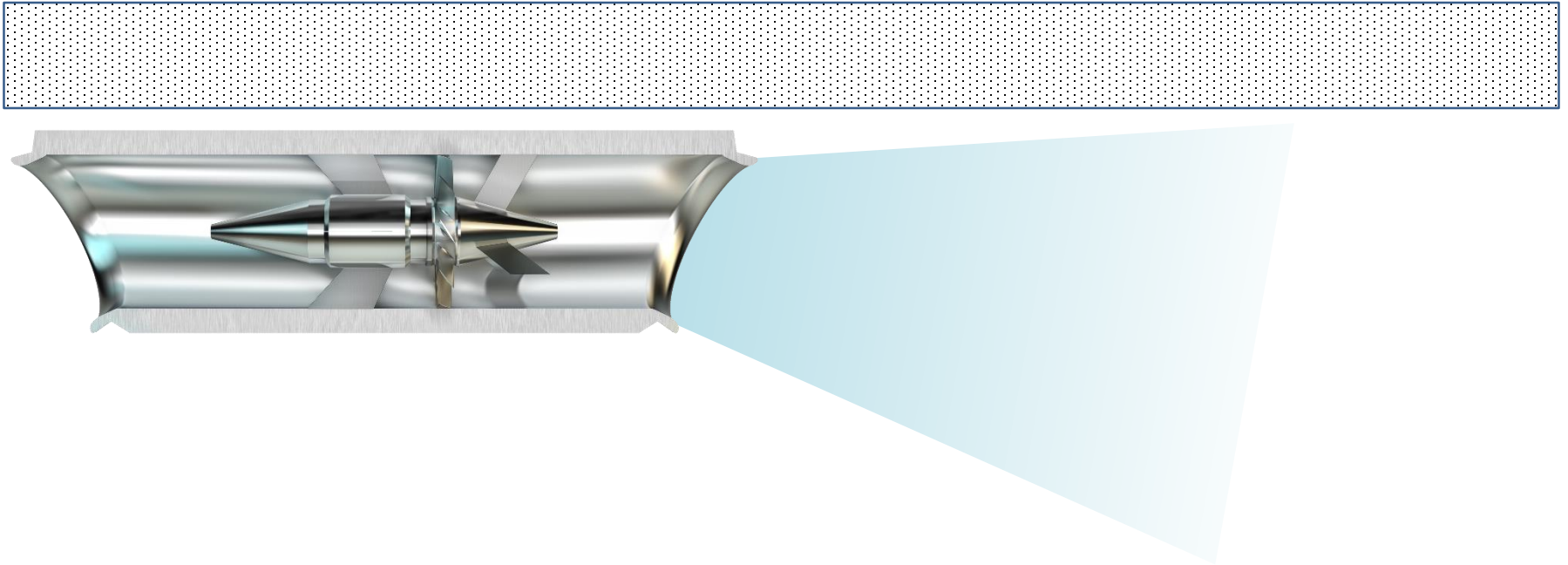

- Deflect the discharged jet to reduce aerodynamic friction
- In-tunnel thrust increased by up to 100%

How the Shaped Nozzles Work

- The reversible tunnel ventilation system with shaped nozzles can increase the in-tunnel aerodynamic thrust by up to 100%, with reduced power consumption.
- The shaped nozzles turn the airstream away from the tunnel soffit and walls. This reduces surface friction, minimising the Coanda Effect.

Computational Fluid Dynamics (CFD)

- 3D CFD calculations have been used extensively in the design.
- They have confirmed the advantages of the shaped nozzles both in bench thrust tests (in the factory) and also within tunnels.

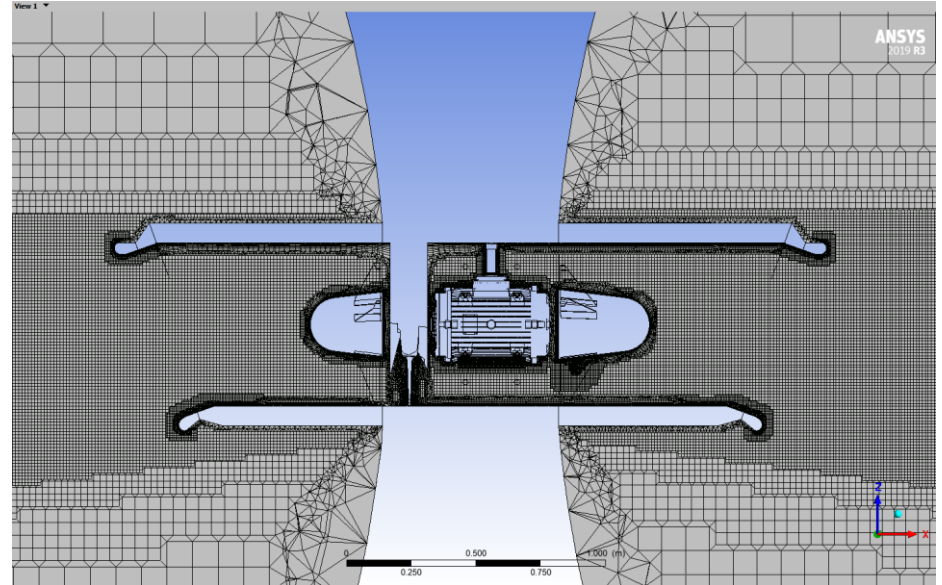

Benefits of the Shaped Nozzles

- Reduced number of jet fans required, hence less procurement and maintenance costs
- Reduced cabling requirements
- Less power consumption
- More energy-efficient, sustainable solution

Aerodynamic Effects

- Reducing the Coanda effect (i.e. the flow is turned away from the tunnel soffit).
- Static pressure recovery downstream of the fan (due to an increase in silencer cross-sectional area).
- Increased mass flowrate through the fan (due to reduced inlet and outlet pressure drops).
- The confining effects of the tunnel soffit on the silencer inlet are reduced, because the silencer inlet area is directed away from the tunnel soffit.
- Reduced discharge velocity, leading to lower shear stress at the tunnel soffit.

Factory Tests

A full range of thrust and acoustic tests have been carried out for 1.25m and 0.8m internal diameter jet fans with shaped nozzles.





Full-scale tunnel tests & CFD

Full-Scale Tunnel Tests

Jet fans with shaped nozzles have been successfully tested in the following tunnels:

- Montgomery Tunnel, Brussels, Belgium (100% increase in thrust compared to conventional jet fans)
- Queensway Tunnel, Liverpool, England (30% increase in thrust compared to a conventional jet fan)

Montgomery Tunnel, Brussels



Montgomery Tunnel Cross-Section

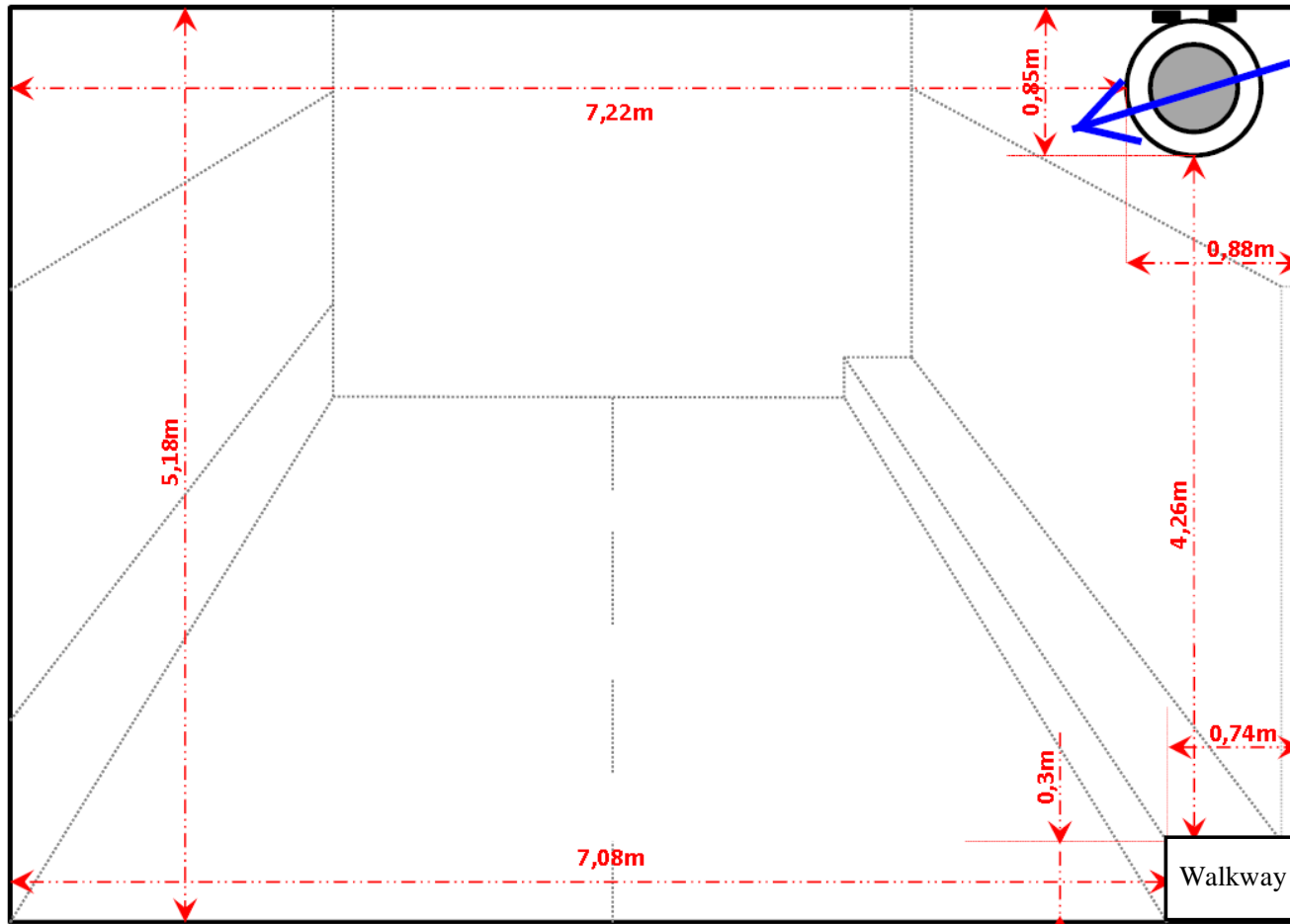

Montgomery Tunnel, Brussels

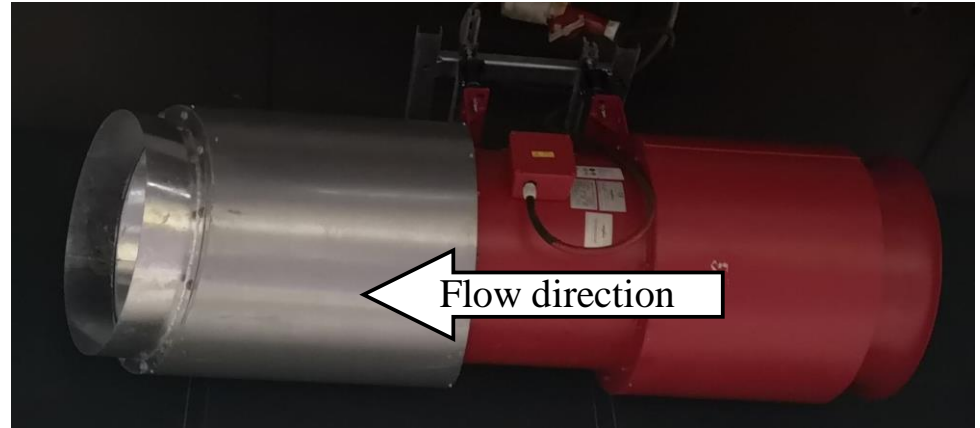
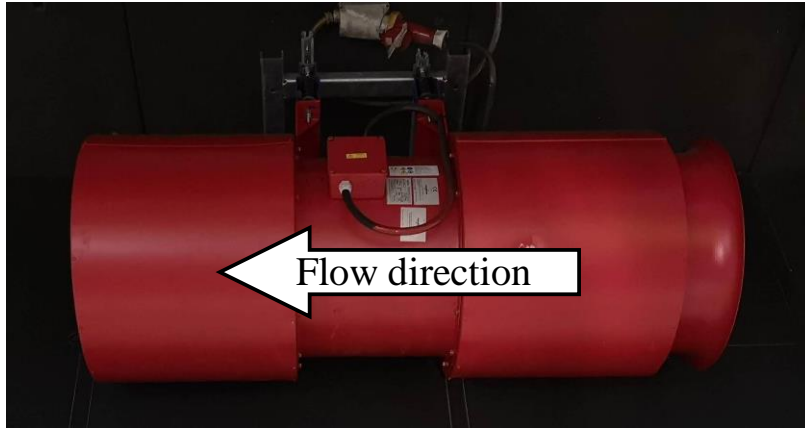

Experimental comparison between unidirectional jet fans (3 conventional jet fans and 3 jet fans with shaped nozzles) undertaken; 100% additional thrust with shaped nozzle, measured by ULB University.

Measurement Grid at North Portal



5 x 5 = 25
points on
cross-section
measured near
the north
portal, in
accordance
with BS EN
ISO 5802:
2008+A1:2015

CFD Calculations

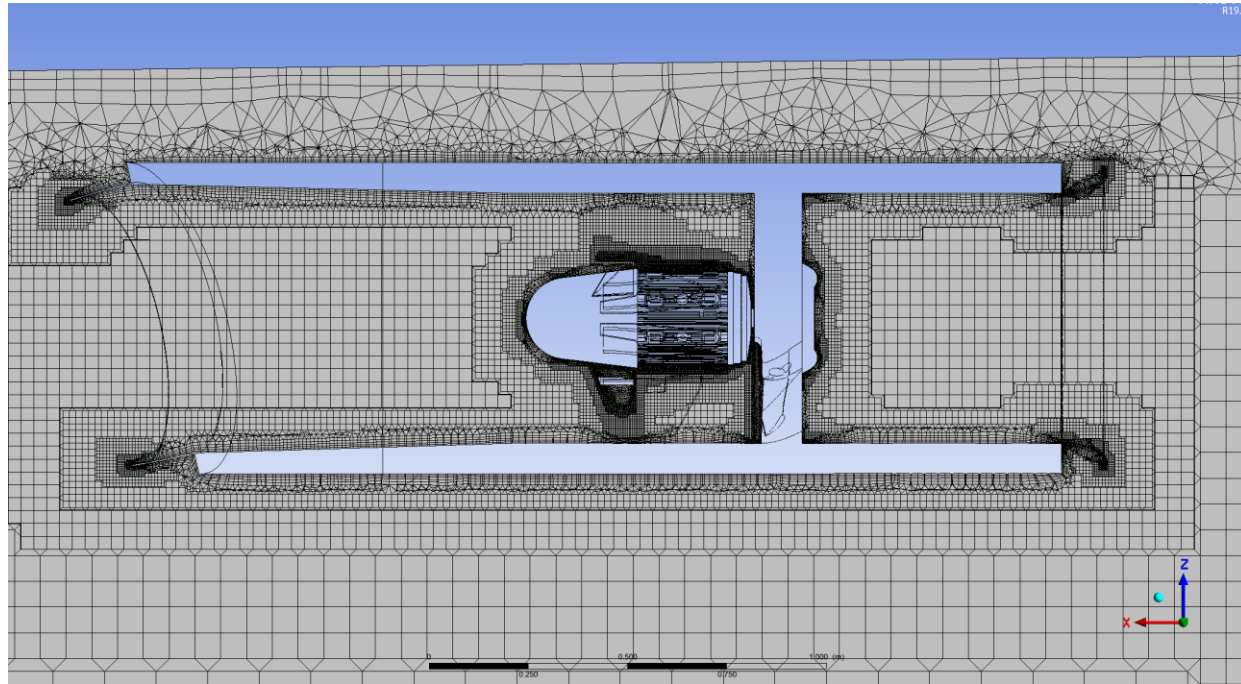

100% increase in thrust was confirmed by 3D CFD calculations.

Mersey Queensway Tunnel – Rendel Street Branch



Rendel Street Branch Tunnel

(600 m long x 7 m wide approximately)



Airflow Measurements



6 x 6 = 36 points on
cross-section
measured 140 m
away from jet fan, in
accordance with BS
EN ISO 5802:
2008+A1:2015

Installation of Jet Fan with Shaped Nozzles



Approximately 30% increase in thrust was measured compared to a conventional jet fan, with no increase in power consumption.

3D CFD Calculations

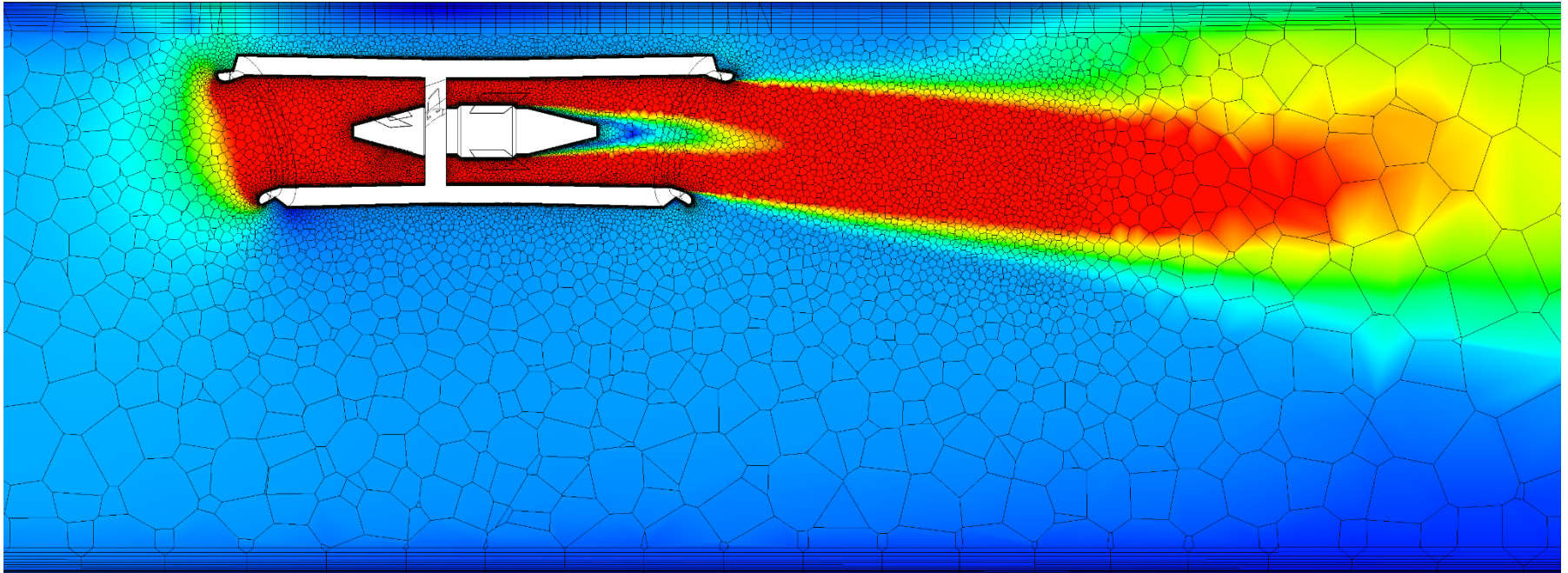

Confirmation of the additional thrust, on the basis of ANSYS Fluent modelling.



How to Select the Correct Jet Fan Technology

Jet Fan Technologies

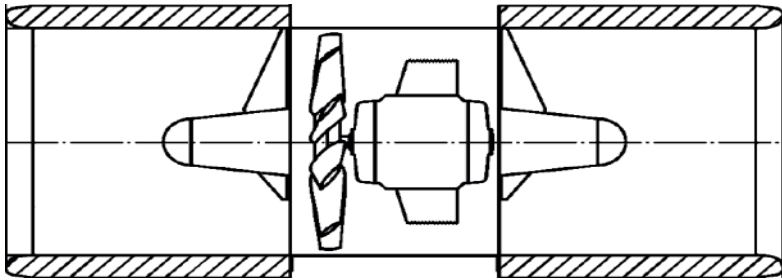

Conventional
jet fan

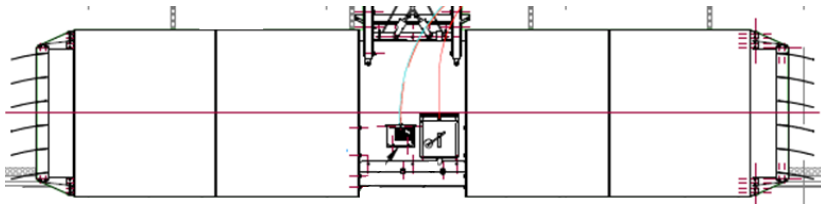

Jet fan with
deflectors

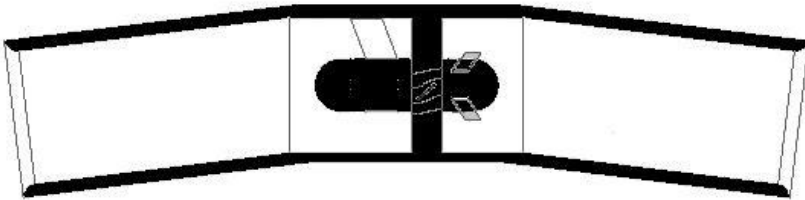

Slanted
silencers

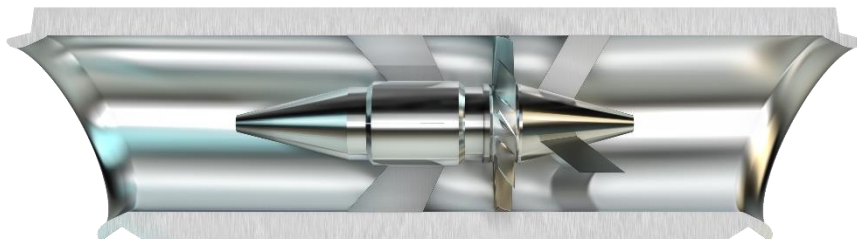

Shaped
nozzles

Oldest

Time

Most
recent

Issues to Consider

- Jet deflection
- Compactness
- Jet throw extension
- Noise regeneration
- Deflector metal fatigue risk
- Additional power consumption
- Loss of bench thrust
- Risk of bearing damage



Project example – Rize Tunnel, Turkey

Rize Tunnel, Turkey



Scope of work

- Establish a baseline of required conventional jet fans without fire suppression
- Design the required number of jetfans with shaped nozzles plus low-pressure mist fire suppression system

Software used

- IDA Road Tunnel Ventilation
- Calculates pressure, airflow, temperature as well as CO and NOx concentrations in complex tunnel networks

Case setup

- Tunnel n° 3 modelled (2 bores)
- Details of the geometry (length, slope and fans location) as per design drawings
- Each bore calculated independently
- Traffic stops at fire location, and backs up all the way to the entrance portal

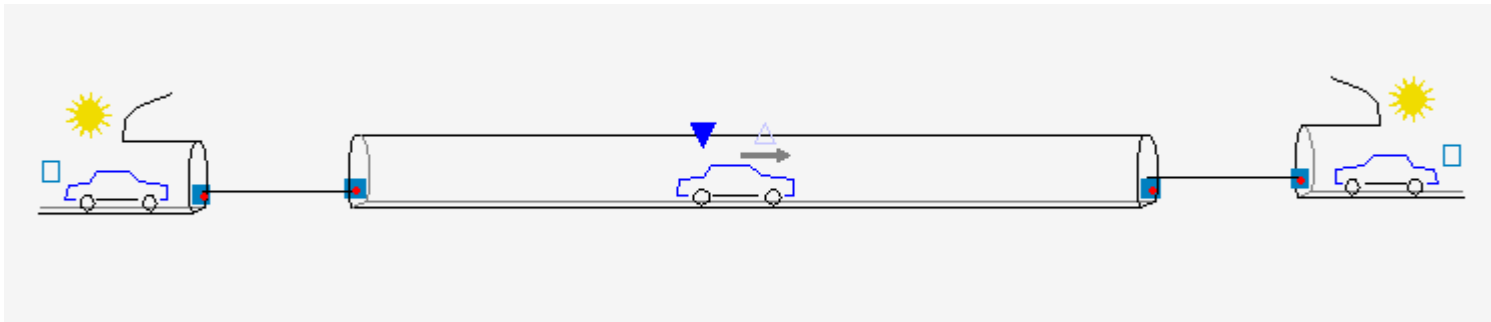

Layout of the system used in the simulation

Conventional Jet Fans

- Aerodynamic thrust provided by each jet fan:

$$T = \eta_i \cdot \rho A_A v_A (v_A - v_\infty)$$

- Where:
- η_i is the installation efficiency
- A_A is the cross section of the jet fan outlet,
- v_A the average fan discharge velocity and
- v_∞ the velocity in the tunnel beyond the direct influence of the jet fan intake and discharge
- Assuming an installation efficiency of 0.71 (conventional jet fan):
 - Jetfan bench thrust should be 1338 N at a discharge velocity of 31.4 m/s and an air density of 1.2 kg/m³.
 - The power consumption per jet fan was assumed to be 30 kW.

Fire Heat Release Rate

- Unsuppressed fire heat release rate: 100 MW
- Due to activation of suppression system, fire heat release rate drops to 40 MW
- 50% of the suppressed fire heat release rate (20MW) assessed to be convective
- Any fan within 120m downstream or 30m upstream from the fire is considered to be damaged (conservative assumption)
- Fire locations: 7 locations considered, 500m apart from each other

Left Tube Operating Fans – Baseline Design

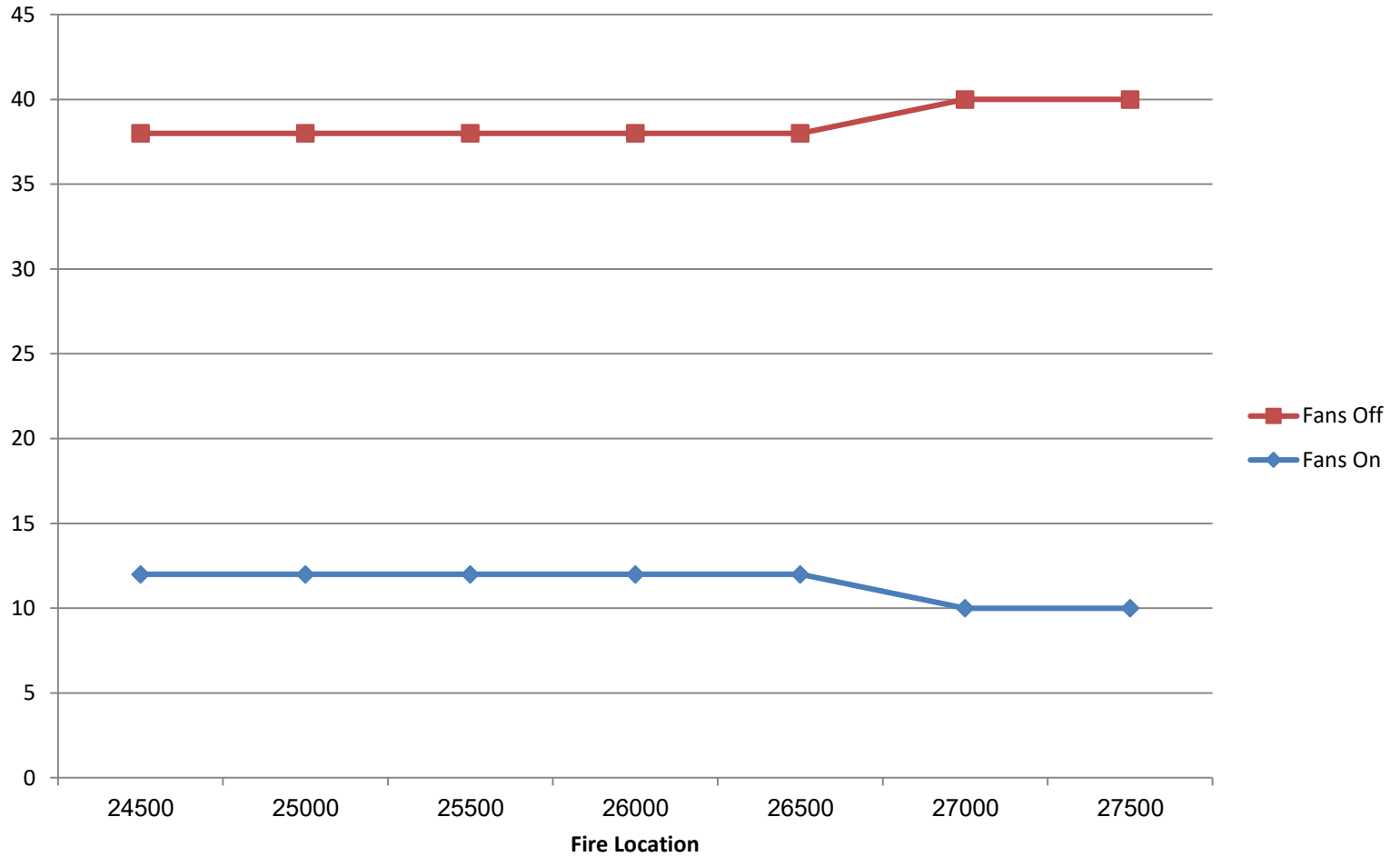

Right Tube Operating Fans – Baseline Design

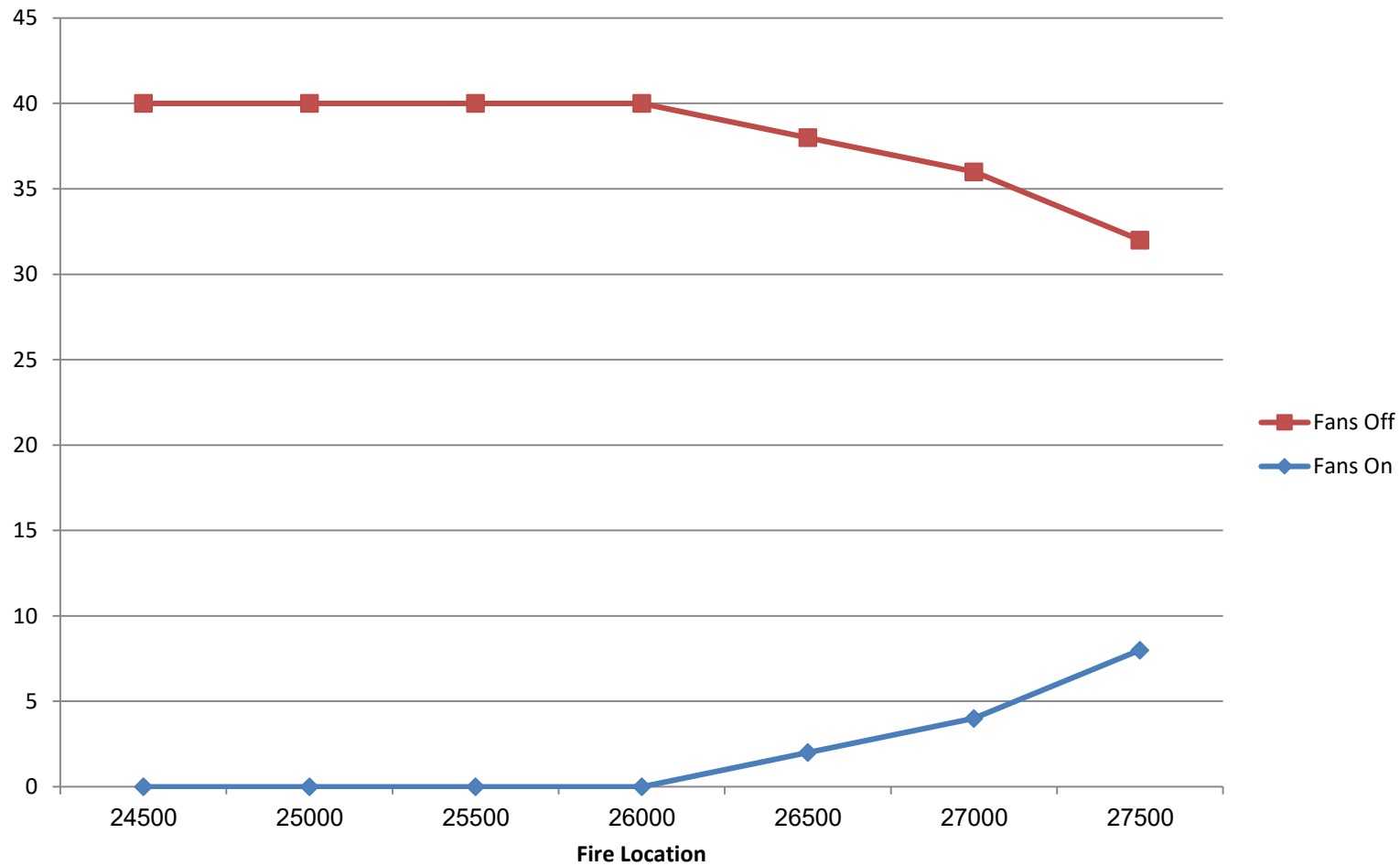

Combination of fire suppression and jet fans with shaped nozzles

- Required number of fans for smoke ventilation is reduced by at least 50%
- Still require an allowance for damage due to fire, but arguably only for one bank of fans (not two)
- Allowance for fans under maintenance
- Check ventilation for air quality during traffic congestion

Rize Tunnel, South Bore

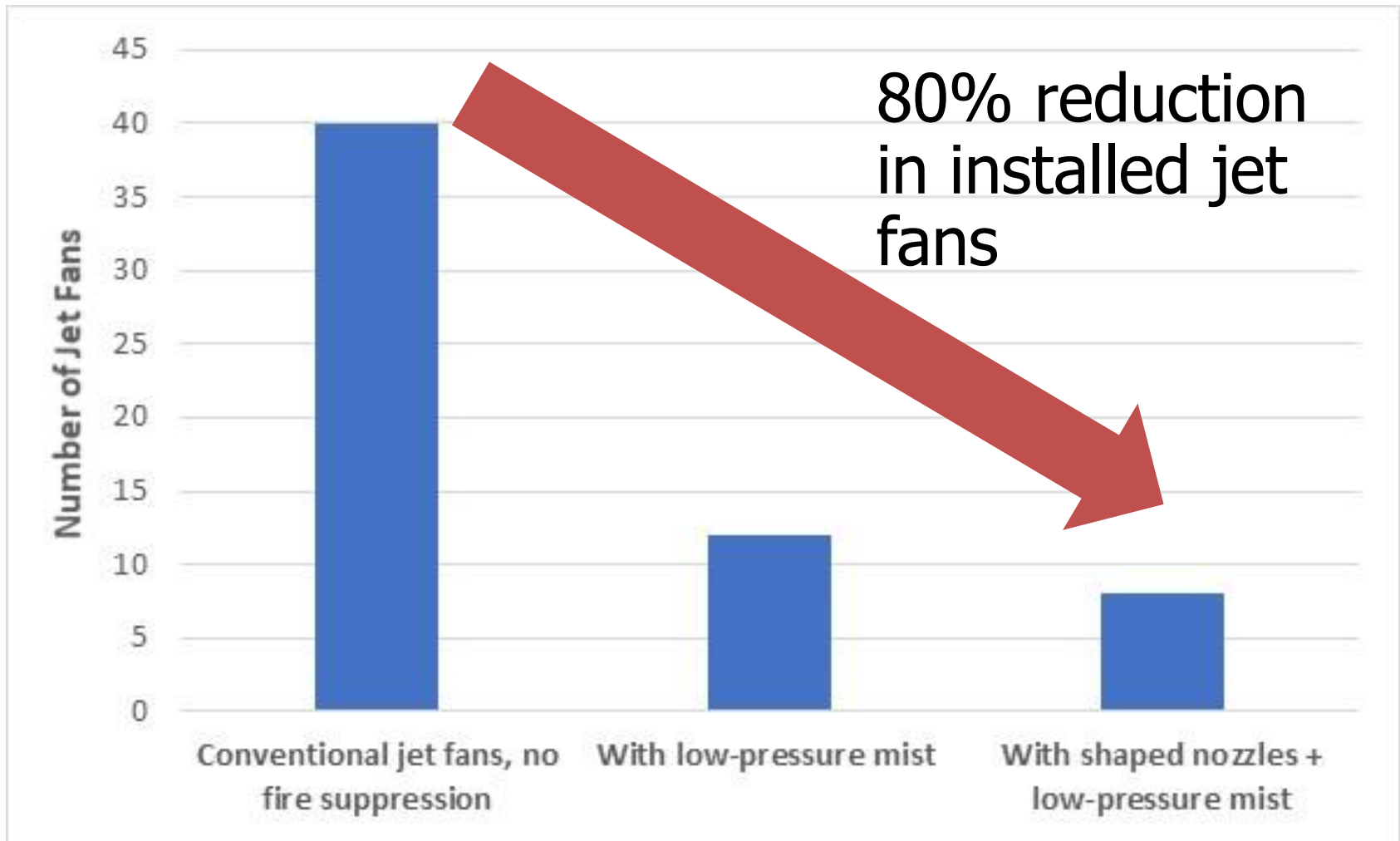

Summary

- Longitudinal tunnel ventilation with jet fans
- Sources of inefficiency
- Jet fans with shaped nozzles
- Tunnel measurements and CFD
- Selection of correct jet fan technology
- Project example

Any Questions?

Dr. Fathi Tarada
MoJet Ventilation, UK
info@mojet.global

Eng. Shadi Khatib
6Beavers, Israel
Shadi@6beavers.com